

# CoolBox™ XT Instructions for Use

## Introduction

CoolBox XT is a portable workstation designed for maintaining sample temperatures below 4°C on the bench top, without the use of wet ice or electricity. The dual-phase conductive XT Cooling Core or XT Freezing Core provides the cooling source when a thermo-conductive CoolRack or CoolSink tube and plate module is placed on top. The core and sample module in combination ensure uniform well-to-well temperature throughout the cooling period regardless of sample position. The XT Cooling Core can maintain sample temperature from 0.5 to 4°C for over 16 hours; the XT Freezing Core can maintain frozen samples for up to 10 hours; using dry ice in the base provides ultra-cold temperature (-78°C) for snap freezing samples in tubes or plates. (For a list of CoolRack and CoolSink modules that are compatible with the CoolBox XT, see below.)

## Quick Start

---

- Remove XT Cooling Core from -20°C freezer and place in the base of CoolBox XT. If using collar place on top of base.
- When temperature strip on XT Cooling Core registers 1°C, place CoolRack™ or CoolSink™ sample module on top.
- Load samples.

### CAUTION

- Lift CoolBox XT from the bottom using the handholds on the sides.
- Always use two hands when carrying or lifting the CoolBox XT.
- Avoid touching the top metal surface of the XT Cooling Core and XT Freezing Core when removing from freezer.

**ATTENTION:** To ensure your samples do not freeze and to get maximum cooling duration, please refer to the detailed instructions that follow.

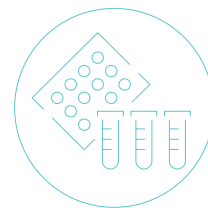

# CoolBox™ XT

## Instructions for Use

### Assembly of CoolBox XT

The CoolBox XT System consists of a high-density foam base, collar and lid, and a reusable XT Cooling Core. A CoolBox XT Workstation also includes a CoolRack or CoolSink tube or plate module to hold and organize samples. When placed on top of the XT Cooling or Freezing Core, the modules and samples rapidly equilibrate to the temperature of the XT Core. Samples can be placed in the CoolRack or CoolSink module either before or after the module is placed in the CoolBox XT. When used with CoolSink plate modules the magnetized collar is not required and can be removed for easy access when working; however, to obtain the maximum cooling duration, we recommend using the collar whenever possible.

1. Place XT Cooling Core, XT Freezing Core or dry ice in CoolBox XT base.
2. Fit magnetized collar on top of base, seating it securely.
3. Place CoolRack or CoolSink module of choice on top of core or dry ice.
4. Place lid on CoolBox XT when not processing samples.

Figure 1

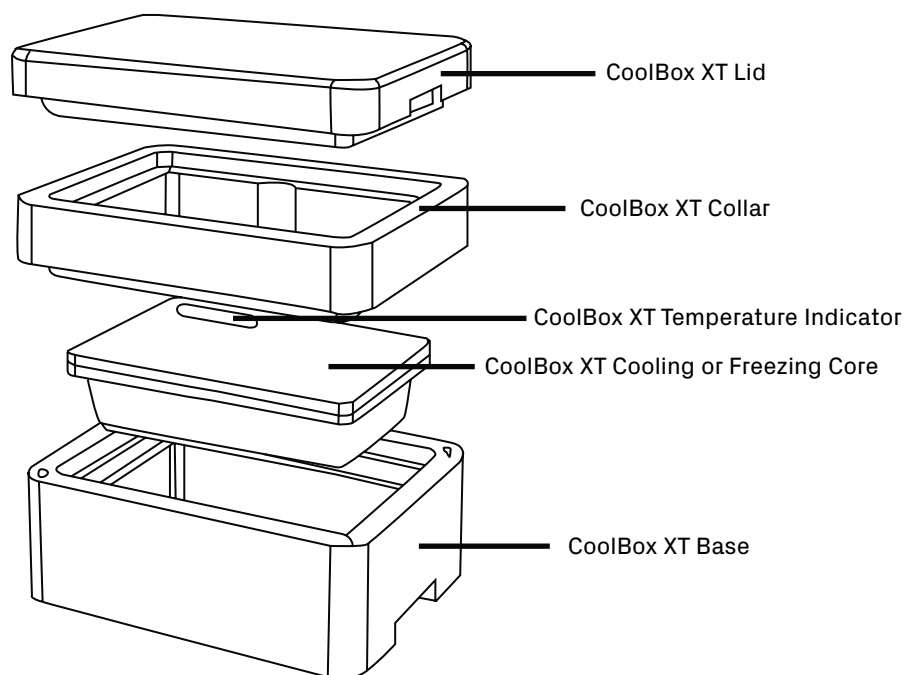

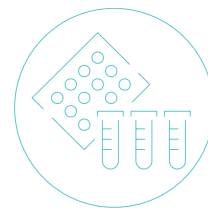

# CoolBox™ XT

## Instructions for Use

### Using XT Cooling Core for Maintaining Samples at 0.5 to 4°C Containing Samples

Temperature Working Range	CoolBox XT Cooling Source	Temperature Duration* Closed Lid
0.5 to 4.0°C	Over 10 hours	Over 16 hours

Freeze XT Cooling Core in a -20°C freezer for at least 12 hours. XT Cooling Core should be stored in -20°C freezer when not in use so it is ready when needed.

**Note:** Freezing XT Cooling Cores for less than the specified time will result in decreased cooling duration.

#### When Using a Pre-chilled (4°C) CoolRack or CoolSink Module

- Remove the XT Cooling Core from the freezer and place on benchtop for approximately 10 minutes. When the temperature indicator displays 1°C, the XT Cooling Core is ready to use.

**ATTENTION!:** Failure to allow XT Cooling Core to reach 1°C may result in sample freezing.

- Place XT Cooling Core into CoolBox XT base.
- Fit magnetized collar onto CoolBox XT base, seating it securely.
- Place the CoolRack or CoolSink module of choice onto XT Cooling Core.
- Load samples.
- Place lid on CoolBox XT when not processing samples to maximize cooling duration.

#### When Using Room Temperature CoolRack or CoolSink Modules

- Remove the XT Cooling Core from the freezer and place into CoolBox XT base.
- Fit magnetized collar onto CoolBox XT base, seating it securely.
- Place CoolRack or CoolSink module directly onto cooling core and allow to equilibrate to 4°C (approximately 8 minutes).
- Load samples.
- Place lid on CoolBox XT when not processing samples to maximize cooling duration.

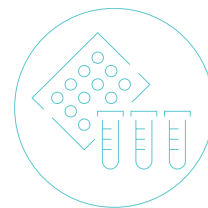

# CoolBox™ XT

## Instructions for Use

### Using Optional XT Freezing Core for Maintaining Samples at -20 to 0°C

Temperature Working Range	CoolBox XT Cooling Source	Freezer Temperature	Temperature Duration* Open Lid	Temperature Duration* Closed Lid
-20 to 0°C	XT Freezing Core	-20°C	Over 5 hours	Over 8 hours
-20 to 0°C	XT Freezing Core	-80°C	Over 8 hours	Over 12 hours

Freeze XT Freezing Core in a -20°C freezer for at least 12 hours, or for a faster start, freeze in a -80°C freezer for at least 6 hours. Freezing in a -80°C freezer also prolongs cooling duration. XT Freezing Core should be stored in a -20°C or -80°C freezer when not in use so it is ready when needed.

**Note:** Freezing XT Cooling Cores for less than the specified time will result in decreased cooling duration.

#### When Using a Pre-chilled (10°C or less) CoolRack or CoolSink Module

- Remove two XT Freezing Core units from the freezer and place into CoolBox XT base.
- Fit magnetized collar onto the base of CoolBox XT, seating it securely.
- Place the CoolRack or CoolSink module of choice onto XT Freezing Core.
- Load samples.
- Place lid on CoolBox XT when not processing samples to maximize cooling duration.

#### When Using Room Temperature CoolRack or CoolSink Modules

- Remove the XT Cooling Core units from the freezer and place into CoolBox XT base.
- Fit magnetized collar onto CoolBox XT base, seating it securely.
- Place the room temperature CoolRack or CoolSink module of choice onto core and allow to equilibrate to 4°C (approximately 8 minutes).
- Load samples
- Place lid on CoolBox XT when not processing samples to maximize cooling duration.

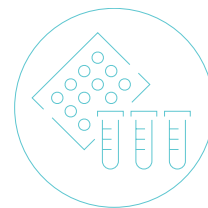

# CoolBox™ XT

## Instructions for Use

### Using Dry Ice for Maintaining or Snap-Freezing Samples at -78°C

Temperature Working Range	CoolBox XT Cooling Source	Temperature Duration Open Lid	Temperature Duration Closed Lid
-78°C	200ml dry ice	Over 4 hours	Over 5 hours

- Remove the XT Cooling or Freezing Core from the CoolBox XT base.
- Fill the base of the CoolBox XT with approximately 200ml of pulverized dry ice.
- Fit magnetized collar onto the base of CoolBox XT, seating it securely.
- Place the CoolRack or CoolSink module directly onto dry ice and allow module to equilibrate to -78°C (approximately 7-8 minutes).
- Load samples.
- If snap-freezing, freezing will occur in 7-10 minutes depending upon sample volume and type.

**Note:** The thermo-conductive design of the CoolRack and CoolSink modules ensures uniform well-to-well temperature regardless of the consistency of the dry ice.

### Cooling Duration

Temperature Working Range	CoolBox XT Cooling Source	Temperature Duration* Open Lid	Temperature Duration* Closed Lid
-0.5 to 4°C	XT Cooling Core	Over 10 hours	Over 16 hours
-20 to 0°C	XT Freezing Core	Over 5 hours	Over 8 hours
-78°C	200ml Dry Ice	Over 4 hours	Over 5 hours

\*All tests were performed using a CoolRack XT M24 loaded with 24 TruCool® 2.0ml microcentrifuge tubes filled with 1.5 ml water. Actual performance may vary depending upon CoolRack module employed, sample load, initial sample temperature, ambient temperature, air currents, and other conditions.

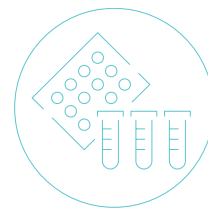

# CoolBox™ XT

## Instructions for Use

### CoolBox XT Care and Cleaning

The CoolBox XT housing is constructed from a cross-linked closed-cell dense polyethylene foam. The material has excellent resistance to fluid absorption and abrasion. Do not use the CoolBox XT base for pulverizing dry ice. Maximum temperature exposure: 60°C. Avoid prolonged exposure to UV light sources.

All components including housing, XT Cooling Core and optional XT Freezing Core are compatible with repeated and prolonged cryogenic temperature exposure. All components can be cleaned with aqueous detergents, alcohol, 10% bleach, and acid/base viricide (such as Virkon S) solutions. Rinse with clear water after using cleaning solutions. Do not autoclave.

CoolRack and CoolSink sample modules may be autoclaved, or cleaned with alcohol or 10% bleach.

CoolRack and CoolSink Thermo-Conductive Sample Modules Compatible with CoolBox XT.

### CoolRack and CoolSink Thermo-Conductive Sample Modules Compatible with CoolBox 2XT

#### Automation-Friendly SBS-Footprint Module

Part Number	Description	Accommodates
BCS-529	CoolRack XT PCR96 (AF)	PCR plate, 12 rows of strip wells or 96 200ul tubes
BCS-538	CoolRack XT PCR384 (AF)	One 384-well plate
BCS-523	CoolRack XT M-PCR (AF)	12 1.5ml tubes and 6 rows of strip well tubes
BCS-535	CoolRack XT M24 (AF)	24 1.5ml microfuge tubes
BCS-534	CoolRack XT CFT24 (AF)	24 cryovials "gripping wells" for one-hand opening
BCS-536	CoolSink XT 96F (AF)	One flat-bottom plate
BCS-537	CoolSink 96U (AF)	One 96w u-bottom plate

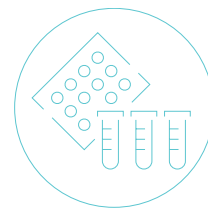

# CoolBox™ XT

## Instructions for Use

### General Purpose Laboratory Sample Modules

Part Number	Description	Accommodates
BCS-163	CoolRack M6	6 × 1.5ml or 2ml microfuge tubes
BCS-125	CoolRack M15	15 × 1.5ml or 2ml microfuge tubes
BCS-127	CoolRack M15-PF	15 × 1.5ml conical microfuge tubes
BCS-126	CoolRack CF15	15 × 1ml or 2ml cryovials
BCS-120	CoolRack PCR96	PCR plate, 12 rows of strip wells or 96 200ul tubes
BCS-139	CoolRack PCR384	384-well plate
BCS-231	CoolRack 96×0.5ml	96 × 0.5ml 2D barcode tubes
BCS-149	CoolRack 96×1ml	96 × 1ml 2D barcode tubes

### CoolBox XT Dimensions and Specifications

Part Number	Accommodates
External dimensions fully assembled	8 x 6.3 x 6 in. (L x W x H) 20.2 x 16 x 15.2 cm (L x W x H)
Internal dimensions with XT Cooling Core loaded and lid in place	5.5 x 3.9 x 3.7 in. (W x L x H) 14 x 9.9 x 9.4 cm (W x L x H)
Weight with XT Cooling Core loaded	2.2 lbs, 1 kg
Re-order part numbers	BCS-502, CoolBox XT System, purple BCS-502G, CoolBox XT System, green BCS-502O, CoolBox XT System, orange BCS-502PK, CoolBox XT System, pink BCS-511, XT Cooling Core BCS-512, XT Freezing Core

**CAUTION:** The products described here are intended for the exclusive use by trained and experienced laboratory and medical personnel. Use of dry ice can be dangerous. Direct skin contact with dry ice or metal components that have been in contact with dry ice can cause freezing injury. Always use appropriate protective equipment for eyes and skin when handling dry ice and cold metal components.